

isc Silicon PNP Power Transistor

2SA1441

DESCRIPTION

- Collector-Emitter Sustaining Voltage-
: $V_{CEO(SUS)} = -60V(\text{Min})$
- High DC Current Gain-
: $h_{FE} = 100(\text{Min})@ (V_{CE} = -2V, I_C = -1A)$
- Low Saturation Voltage-
: $V_{CE(sat)} = -0.3V(\text{Max})@ (I_C = -3A, I_B = -0.15A)$

APPLICATIONS

- This type of power transistor is developed for high-speed switching and features a high h_{FE} at low $V_{CE(sat)}$, which is ideal for use as a driver in DC/DC converters and actuators.

ABSOLUTE MAXIMUM RATINGS($T_a=25^\circ\text{C}$)

SYMBOL	PARAMETER	VALUE	UNIT
V_{CBO}	Collector-Base Voltage	-100	V
V_{CEO}	Collector-Emitter Voltage	-60	V
V_{EBO}	Emitter-Base Voltage	-7.0	V
I_C	Collector Current-Continuous	-5.0	A
I_{CM}	Collector Current-Pulse	-10	A
I_B	Base Current-Continuous	-2.5	A
P_T	Total Power Dissipation @ $T_C=25^\circ\text{C}$	25	W
	Total Power Dissipation @ $T_a=25^\circ\text{C}$	2.0	
T_J	Junction Temperature	150	$^\circ\text{C}$
T_{stg}	Storage Temperature	-55~150	$^\circ\text{C}$

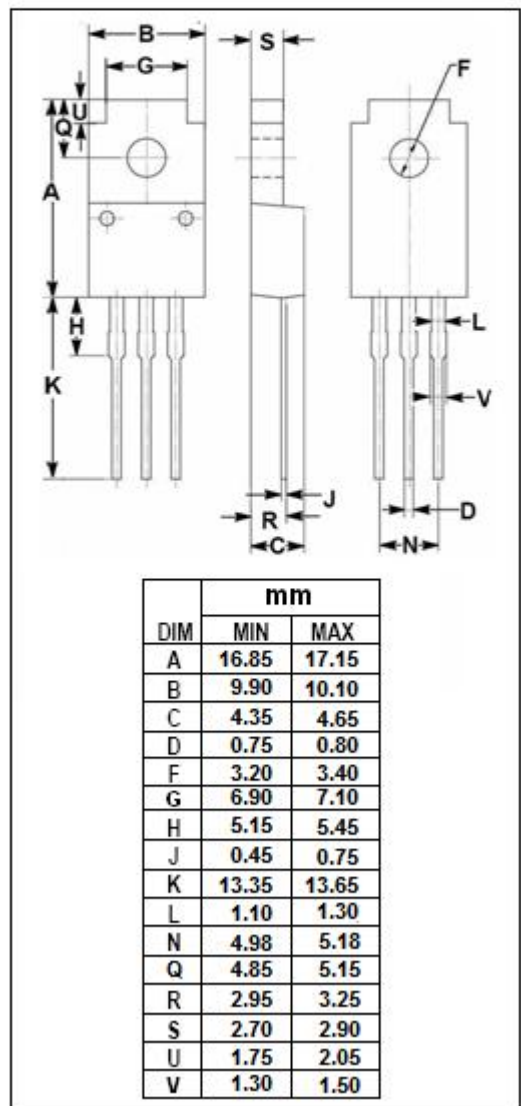
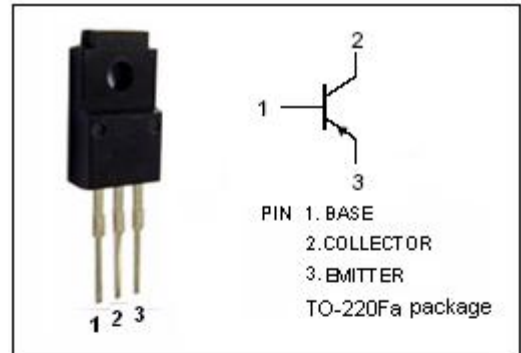

isc Silicon PNP Power Transistor

2SA1441

ELECTRICAL CHARACTERISTICS

T_j=25°C unless otherwise specified

SYMBOL	PARAMETER	CONDITIONS	MIN	TYP.	MAX	UNIT
V _{CEO(SUS)}	Collector-Emitter Sustaining Voltage	I _C = -3.0A ; I _B = -0.3A, L= 1mH	-60			V
V _{CES(SUS)}	Collector-Emitter Sustaining Voltage	I _C = -3.0A ; I _{B1} =-I _{B2} = -0.3A, V _{BE(OFF)} =1.5V, L=180 μ H,clamped	-60			V
V _{CE(sat)-1}	Collector-Emitter Saturation Voltage	I _C = -3A; I _B = -0.15A			-0.3	V
V _{CE(sat)-2}	Collector-Emitter Saturation Voltage	I _C = -4A; I _B = -0.2A			-0.5	V
V _{BE(sat)-1}	Base-Emitter Saturation Voltage	I _C = -3A; I _B = -0.15A			-1.2	V
V _{BE(sat)-2}	Base-Emitter Saturation Voltage	I _C = -4A; I _B = -0.2A			-1.5	V
I _{CBO}	Collector Cutoff Current	V _{CB} = -60V ; I _E =0			-10	μ A
I _{CER}	Collector Cutoff Current	V _{CE} = -60V ; R _{BE} = 50 Ω , T _a =125°C			-1.0	mA
I _{CES}	Collector Cutoff Current	V _{CE} = -60V; V _{BE(off)} = -1.5V V _{CE} = -60V; V _{BE(off)} = -1.5V, T _a =125°C			-10 -1.0	μ A mA
I _{EBO}	Emitter Cutoff Current	V _{EB} = -5V; I _C =0			-10	μ A
h _{FE-1}	DC Current Gain	I _C = -0.5A ; V _{CE} = -2V	100			
h _{FE-2}	DC Current Gain	I _C = -1.0A ; V _{CE} = -2V	100		400	
h _{FE-3}	DC Current Gain	I _C = -3.0A ; V _{CE} = -2V	60			
C _{OB}	Output Capacitance	I _E =0; V _{CB} = -10V; f= 1.0MHz		130		pF
f _T	Current-Gain—Bandwidth Product	I _C =-0.5A ; V _{CE} = -10V		80		MHz

Switching times

t _{on}	Turn-on Time	I _C = -3.0A , R _L = 17 Ω , I _{B1} = -I _{B2} = -0.15A, V _{CC} ≈-50V			0.3	μ s
t _{stg}	Storage Time				1.5	μ s
t _f	Fall Time				0.3	μ s

◆ h_{FE-2} Classifications

M	L	K
100-200	150-300	200-400