

# UC3844B, 45B UC2844B, 45B

## High Performance Current Mode Controllers

The UC3844B, UC3845B series are high performance fixed frequency current mode controllers. They are specifically designed for Off-Line and dc-to-dc converter applications offering the designer a cost-effective solution with minimal external components. These integrated circuits feature an oscillator, a temperature compensated reference, high gain error amplifier, current sensing comparator, and a high current totem pole output ideally suited for driving a power MOSFET.

Also included are protective features consisting of input and reference undervoltage lockouts each with hysteresis, cycle-by-cycle current limiting, a latch for single pulse metering, and a flip-flop which blanks the output off every other oscillator cycle, allowing output deadtimes to be programmed from 50% to 70%.

These devices are available in an 8-pin dual-in-line and surface mount (SO-8) plastic package as well as the 14-pin plastic surface mount (SO-14). The SO-14 package has separate power and ground pins for the totem pole output stage.

The UC3844B has UVLO thresholds of 16 V (on) and 10 V (off), ideally suited for off-line converters. The UC3845B is tailored for lower voltage applications having UVLO thresholds of 8.5 V (on) and 7.6 V (off).

- Trimmed Oscillator for Precise Frequency Control
- Oscillator Frequency Guaranteed at 250 kHz
- Current Mode Operation to 500 kHz Output Switching Frequency
- Output Deadtime Adjustable from 50% to 70%
- Automatic Feed Forward Compensation
- Latching PWM for Cycle-By-Cycle Current Limiting
- Internally Trimmed Reference with Undervoltage Lockout
- High Current Totem Pole Output
- Undervoltage Lockout with Hysteresis
- Low Startup and Operating Current

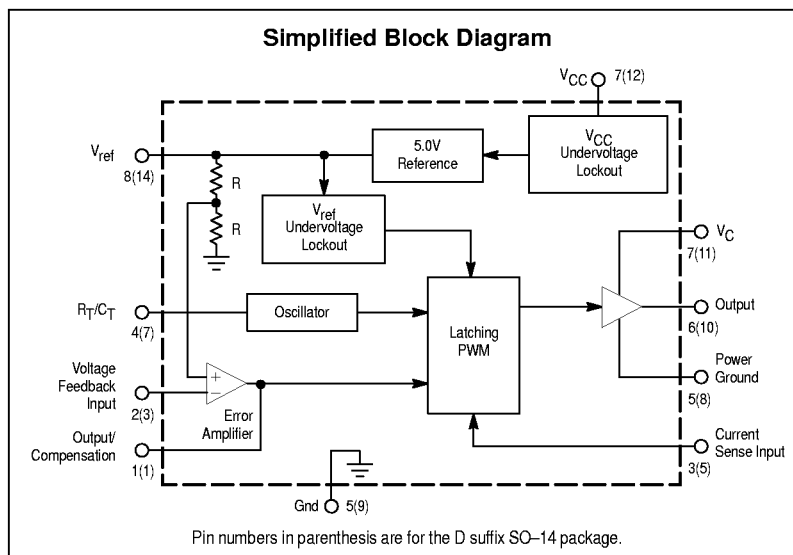

### HIGH PERFORMANCE CURRENT MODE CONTROLLERS

**N SUFFIX**  
PLASTIC PACKAGE  
CASE 626

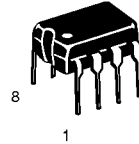

**D1 SUFFIX**  
PLASTIC PACKAGE  
CASE 751  
(SO-8)

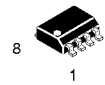

**D SUFFIX**  
PLASTIC PACKAGE  
CASE 751A  
(SO-14)

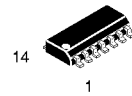

### PIN CONNECTIONS

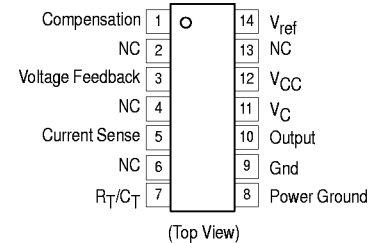
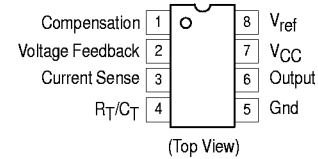

### ORDERING INFORMATION

| Device     | Operating Temperature Range                       | Package |
|------------|---|---------|
| UC384XBD   | $T_A = 0^\circ \text{ to } +70^\circ \text{C}$    | SO-14   |
| UC384XBD1  |   | SO-8    |
| UC384XBN   |   | Plastic |
| UC284XBD   | $T_A = -25^\circ \text{ to } +85^\circ \text{C}$  | SO-14   |
| UC284XBD1  |   | SO-8    |
| UC284XBN   |   | Plastic |
| UC384XBVD  | $T_A = -40^\circ \text{ to } +105^\circ \text{C}$ | SO-14   |
| UC384XBVD1 |   | SO-8    |
| UC384XBVN  |   | Plastic |

X indicates either a 4 or 5 to define specific device part numbers.

# UC3844B, 45B UC2844B, 45B

## MAXIMUM RATINGS

| Rating   | Symbol           | Value                  | Unit               |
|--|------------------|------------------------|--------------------|
| Total Power Supply and Zener Current   | $(I_{CC} + I_Z)$ | 30                     | mA                 |
| Output Current, Source or Sink (Note 1)  | $I_O$            | 1.0                    | A                  |
| Output Energy (Capacitive Load per Cycle)  | W                | 5.0                    | $\mu\text{J}$      |
| Current Sense and Voltage Feedback Inputs  | $V_{in}$         | -0.3 to +5.5           | V                  |
| Error Amp Output Sink Current  | $I_O$            | 10                     | mA                 |
| Power Dissipation and Thermal Characteristics<br>D Suffix, Plastic Package, SO-14 Case 751A<br>Maximum Power Dissipation @ $T_A = 25^\circ\text{C}$<br>Thermal Resistance, Junction-to-Air | $P_D$            | 862                    | mW                 |
|  | $R_{\theta JA}$  | 145                    | $^\circ\text{C/W}$ |
|  | $P_D$            | 702                    | mW                 |
|  | $R_{\theta JA}$  | 178                    | $^\circ\text{C/W}$ |
| D1 Suffix, Plastic Package, SO-8 Case 751<br>Maximum Power Dissipation @ $T_A = 25^\circ\text{C}$<br>Thermal Resistance, Junction-to-Air   | $P_D$            | 1.25                   | W                  |
|  | $R_{\theta JA}$  | 100                    | $^\circ\text{C/W}$ |
| N Suffix, Plastic Package, Case 626<br>Maximum Power Dissipation @ $T_A = 25^\circ\text{C}$<br>Thermal Resistance, Junction-to-Air   | $P_D$            | 1.25                   | W                  |
|  | $R_{\theta JA}$  | 100                    | $^\circ\text{C/W}$ |
| Operating Junction Temperature   | $T_J$            | +150                   | $^\circ\text{C}$   |
| Operating Ambient Temperature<br>UC3844B, UC3845B<br>UC2844B, UC2845B  | $T_A$            | 0 to +70<br>-25 to +85 | $^\circ\text{C}$   |
| Storage Temperature Range  | $T_{stg}$        | -65 to +150            | $^\circ\text{C}$   |

**ELECTRICAL CHARACTERISTICS** ( $V_{CC} = 15\text{ V}$  [Note 2],  $R_T = 10\text{ k}$ ,  $C_T = 3.3\text{ nF}$ . For typical values  $T_A = 25^\circ\text{C}$ , for min/max values  $T_A$  is the operating ambient temperature range that applies [Note 3], unless otherwise noted.)

| Characteristic | Symbol | UC284XB |     |     | UC384XB, XBV |     |     | Unit |
|----------------|--------|---------|-----|-----|--------------|-----|-----|------|
|                |        | Min     | Typ | Max | Min          | Typ | Max |      |

## REFERENCE SECTION

|  |              |      |     |      |      |     |      |                            |
|--|--------------|------|-----|------|------|-----|------|----------------------------|
| Reference Output Voltage ( $I_O = 1.0\text{ mA}$ , $T_J = 25^\circ\text{C}$ )            | $V_{ref}$    | 4.95 | 5.0 | 5.05 | 4.9  | 5.0 | 5.1  | V                          |
| Line Regulation ( $V_{CC} = 12\text{ V to } 25\text{ V}$ )                               | $Reg_{line}$ | -    | 2.0 | 20   | -    | 2.0 | 20   | mV                         |
| Load Regulation ( $I_O = 1.0\text{ mA to } 20\text{ mA}$ )                               | $Reg_{load}$ | -    | 3.0 | 25   | -    | 3.0 | 25   | mV                         |
| Temperature Stability  | $T_S$        | -    | 0.2 | -    | -    | 0.2 | -    | $\text{mV}/^\circ\text{C}$ |
| Total Output Variation over Line, Load, and Temperature                                  | $V_{ref}$    | 4.9  | -   | 5.1  | 4.82 | -   | 5.18 | V                          |
| Output Noise Voltage ( $f = 10\text{ Hz to } 10\text{ kHz}$ , $T_J = 25^\circ\text{C}$ ) | $V_n$        | -    | 50  | -    | -    | 50  | -    | $\mu\text{V}$              |
| Long Term Stability ( $T_A = 125^\circ\text{C}$ for 1000 Hours)                          | S            | -    | 5.0 | -    | -    | 5.0 | -    | mV                         |
| Output Short Circuit Current   | $I_{SC}$     | -30  | -85 | -180 | -30  | -85 | -180 | mA                         |

## OSCILLATOR SECTION

|   |                           |     |     |     |     |     |     |     |
|---|---------------------------|-----|-----|-----|-----|-----|-----|-----|
| Frequency<br>$T_J = 25^\circ\text{C}$<br>$T_A = T_{low}$ to $T_{high}$<br>$T_J = 25^\circ\text{C}$ ( $R_T = 6.2\text{ k}$ , $C_T = 1.0\text{ nF}$ ) | $f_{OSC}$                 | 49  | 52  | 55  | 49  | 52  | 55  | kHz |
|   |                           | 48  | -   | 56  | 48  | -   | 56  |     |
|   |                           | 225 | 250 | 275 | 225 | 250 | 275 |     |
| Frequency Change with Voltage ( $V_{CC} = 12\text{ V to } 25\text{ V}$ )  | $\Delta f_{OSC}/\Delta V$ | -   | 0.2 | 1.0 | -   | 0.2 | 1.0 | %   |
| Frequency Change with Temperature<br>$T_A = T_{low}$ to $T_{high}$  | $\Delta f_{OSC}/\Delta T$ | -   | 1.0 | -   | -   | 0.5 | -   | %   |
| Oscillator Voltage Swing (Peak-to-Peak)   | $V_{OSC}$                 | -   | 1.6 | -   | -   | 1.6 | -   | V   |
| Discharge Current ( $V_{OSC} = 2.0\text{ V}$ )<br>$T_J = 25^\circ\text{C}$<br>$T_A = T_{low}$ to $T_{high}$ (UC284XB, UC384XB)<br>(UC384XBV)        | $I_{dischg}$              | 7.8 | 8.3 | 8.8 | 7.8 | 8.3 | 8.8 | mA  |
|   |                           | 7.5 | -   | 8.8 | 7.6 | -   | 8.8 |     |
|   |                           | -   | -   | -   | 7.2 | -   | 8.8 |     |

**NOTES:** 1. Maximum package power dissipation limits must be observed.

2. Adjust  $V_{CC}$  above the Startup threshold before setting to 15 V.

3. Low duty cycle pulse techniques are used during test to maintain junction temperature as close to ambient as possible.

$T_{low} = 0^\circ\text{C}$  for UC3844B, UC3845B

=  $-25^\circ\text{C}$  for UC2844B, UC2845B

=  $-40^\circ\text{C}$  for UC3844BV, UC3845BV

$T_{high} = +70^\circ\text{C}$  for UC3844B, UC3845B

=  $+85^\circ\text{C}$  for UC2844B, UC2845B

=  $+105^\circ\text{C}$  for UC3844BV, UC3845BV

## UC3844B, 45B UC2844B, 45B

**ELECTRICAL CHARACTERISTICS** ( $V_{CC} = 15\text{ V}$  [Note 2],  $R_T = 10\text{ k}$ ,  $C_T = 3.3\text{ nF}$ . For typical values  $T_A = 25^\circ\text{C}$ , for min/max values  $T_A$  is the operating ambient temperature range that applies [Note 3], unless otherwise noted.)

| Characteristic | Symbol | UC284XB |     |     | UC384XB, XBV |     |     | Unit |
|----------------|--------|---------|-----|-----|--------------|-----|-----|------|
|                |        | Min     | Typ | Max | Min          | Typ | Max |      |

### ERROR AMPLIFIER SECTION

|  |                            |             |            |          |             |            |                 |               |
|--|----------------------------|-------------|------------|----------|-------------|------------|-----------------|---------------|
| Voltage Feedback Input ( $V_O = 2.5\text{ V}$ )  | $V_{FB}$                   | 2.45        | 2.5        | 2.55     | 2.42        | 2.5        | 2.58            | V             |
| Input Bias Current ( $V_{FB} = 5.0\text{ V}$ )   | $I_{IB}$                   | –           | –0.1       | –1.0     | –           | –0.1       | –2.0            | $\mu\text{A}$ |
| Open Loop Voltage Gain ( $V_O = 2.0\text{ V to }4.0\text{ V}$ )  | $A_{VOL}$                  | 65          | 90         | –        | 65          | 90         | –               | dB            |
| Unity Gain Bandwidth ( $T_J = 25^\circ\text{C}$ )  | BW                         | 0.7         | 1.0        | –        | 0.7         | 1.0        | –               | MHz           |
| Power Supply Rejection Ratio ( $V_{CC} = 12\text{ V to }25\text{ V}$ )   | PSRR                       | 60          | 70         | –        | 60          | 70         | –               | dB            |
| Output Current<br>Sink ( $V_O = 1.1\text{ V}$ , $V_{FB} = 2.7\text{ V}$ )<br>Source ( $V_O = 5.0\text{ V}$ , $V_{FB} = 2.3\text{ V}$ )   | $I_{Sink}$<br>$I_{Source}$ | 2.0<br>–0.5 | 12<br>–1.0 | –<br>–   | 2.0<br>–0.5 | 12<br>–1.0 | –<br>–          | mA            |
| Output Voltage Swing<br>High State ( $R_L = 15\text{ k to ground}$ , $V_{FB} = 2.3\text{ V}$ )<br>Low State ( $R_L = 15\text{ k to }V_{ref}$ , $V_{FB} = 2.7\text{ V}$ )<br>(UC284XB, UC384XB)<br>(UC384XBV) | $V_{OH}$<br>$V_{OL}$       | 5.0<br>–    | 6.2<br>0.8 | –<br>1.1 | 5.0<br>–    | 6.2<br>0.8 | –<br>1.1<br>1.2 | V             |

### CURRENT SENSE SECTION

|  |                   |           |          |           |              |            |              |               |
|--|-------------------|-----------|----------|-----------|--------------|------------|--------------|---------------|
| Current Sense Input Voltage Gain (Notes 4 & 5)<br>(UC284XB, UC384XB)<br>(UC384XBV) | $A_V$             | 2.85<br>– | 3.0<br>– | 3.15<br>– | 2.85<br>2.85 | 3.0<br>3.0 | 3.15<br>3.25 | V/V           |
| Maximum Current Sense Input Threshold (Note 4)<br>(UC284XB, UC384XB)<br>(UC384XBV) | $V_{th}$          | 0.9<br>–  | 1.0<br>– | 1.1<br>–  | 0.9<br>0.85  | 1.0<br>1.0 | 1.1<br>1.1   | V             |
| Power Supply Rejection Ratio<br>( $V_{CC} = 12\text{ V to }25\text{ V}$ ) (Note 4) | PSRR              | –         | 70       | –         | –            | 70         | –            | dB            |
| Input Bias Current   | $I_{IB}$          | –         | –2.0     | –10       | –            | –2.0       | –10          | $\mu\text{A}$ |
| Propagation Delay (Current Sense Input to Output)                                  | $t_{PLH}(In/Out)$ | –         | 150      | 300       | –            | 150        | 300          | ns            |

### OUTPUT SECTION

|  |                              |                              |                                      |                                |                                 |  |                                  |    |
|--|------------------------------|------------------------------|--------------------------------------|--------------------------------|---------------------------------|--|----------------------------------|----|
| Output Voltage<br>Low State ( $I_{Sink} = 20\text{ mA}$ )<br>( $I_{Sink} = 200\text{ mA}$ , UC284XB, UC384XB)<br>( $I_{Sink} = 200\text{ mA}$ , UC384XBV)<br>High State ( $I_{Source} = 20\text{ mA}$ , UC284XB, UC384XB)<br>( $I_{Source} = 20\text{ mA}$ , UC384XBV)<br>( $I_{Source} = 200\text{ mA}$ ) | $V_{OL}$<br><br><br>$V_{OH}$ | –<br>–<br>–<br>13<br>–<br>12 | 0.1<br>1.6<br>–<br>13.5<br>–<br>13.4 | 0.4<br>2.2<br>–<br>–<br>–<br>– | –<br>–<br>–<br>13<br>12.9<br>12 | 0.1<br>1.6<br>1.6<br>13.5<br>–<br>13.4 | 0.4<br>2.2<br>2.3<br>–<br>–<br>– | V  |
| Output Voltage with UVLO Activated<br>$V_{CC} = 6.0\text{ V}$ , $I_{Sink} = 1.0\text{ mA}$   | $V_{OL}(UVLO)$               | –                            | 0.1                                  | 1.1                            | –                               | 0.1                                    | 1.1                              | V  |
| Output Voltage Rise Time ( $C_L = 1.0\text{ nF}$ , $T_J = 25^\circ\text{C}$ )  | $t_r$                        | –                            | 50                                   | 150                            | –                               | 50                                     | 150                              | ns |
| Output Voltage Fall Time ( $C_L = 1.0\text{ nF}$ , $T_J = 25^\circ\text{C}$ )  | $t_f$                        | –                            | 50                                   | 150                            | –                               | 50                                     | 150                              | ns |

### UNDERVOLTAGE LOCKOUT SECTION

|   |                      |            |           |           |             |           |             |   |
|---|----------------------|------------|-----------|-----------|-------------|-----------|-------------|---|
| Startup Threshold<br>UCX844B, BV<br>UCX845B, BV                       | $V_{th}$             | 15<br>7.8  | 16<br>8.4 | 17<br>9.0 | 14.5<br>7.8 | 16<br>8.4 | 17.5<br>9.0 | V |
| Minimum Operating Voltage After Turn–On<br>UCX844B, BV<br>UCX845B, BV | $V_{CC}(\text{min})$ | 9.0<br>7.0 | 10<br>7.6 | 11<br>8.2 | 8.5<br>7.0  | 10<br>7.6 | 11.5<br>8.2 | V |

**NOTES:** 2. Adjust  $V_{CC}$  above the Startup threshold before setting to 15 V.

3. Low duty cycle pulse techniques are used during test to maintain junction temperature as close to ambient as possible.

$T_{low} = 0^\circ\text{C}$  for UC3844B, UC3845B       $T_{high} = +70^\circ\text{C}$  for UC3844B, UC3845B  
 $= -25^\circ\text{C}$  for UC2844B, UC2845B       $= +85^\circ\text{C}$  for UC2844B, UC2845B  
 $= -40^\circ\text{C}$  for UC3844BV, UC3845BV       $= +105^\circ\text{C}$  for UC3844BV, UC3845BV

4. This parameter is measured at the latch trip point with  $V_{FB} = 0\text{ V}$ .

5. Comparator gain is defined as:  $A_V = \frac{\Delta V_{\text{Output/Compensation}}}{\Delta V_{\text{Current Sense Input}}}$

# UC3844B, 45B UC2844B, 45B

**ELECTRICAL CHARACTERISTICS** ( $V_{CC} = 15\text{ V}$  [Note 2],  $R_T = 10\text{ k}$ ,  $C_T = 3.3\text{ nF}$ . For typical values  $T_A = 25^\circ\text{C}$ , for min/max values  $T_A$  is the operating ambient temperature range that applies [Note 3], unless otherwise noted.)

| Characteristic  | Symbol       | UC284XB |     |     | UC384XB, XBV |     |     | Unit |
|---|--------------|---------|-----|-----|--------------|-----|-----|------|
|   |              | Min     | Typ | Max | Min          | Typ | Max |      |
| <b>PWM SECTION</b>  |              |         |     |     |              |     |     |      |
| Duty Cycle  |              |         |     |     |              |     |     |      |
| Maximum (UC284XB, UC384XB)  | $DC_{(max)}$ | 47      | 48  | 50  | 47           | 48  | 50  | %    |
| Minimum (UC384XBV)  | $DC_{(min)}$ | –       | –   | –   | 46           | 48  | 50  |      |
| Minimum   | $DC_{(min)}$ | –       | –   | 0   | –            | –   | 0   |      |
| <b>TOTAL DEVICE</b>   |              |         |     |     |              |     |     |      |
| Power Supply Current  | $I_{CC}$     |         |     |     |              |     |     | mA   |
| Startup ( $V_{CC} = 6.5\text{ V}$ for UCX845B,<br>14 V for UCX844B, BV) |              | –       | 0.3 | 0.5 | –            | 0.3 | 0.5 |      |
| Operating (Note 2)  |              | –       | 12  | 17  | –            | 12  | 17  |      |
| Power Supply Zener Voltage ( $I_{CC} = 25\text{ mA}$ )                  | $V_Z$        | 30      | 36  | –   | 30           | 36  | –   | V    |

**NOTES:** 2. Adjust  $V_{CC}$  above the Startup threshold before setting to 15 V.  
 3. Low duty cycle pulse techniques are used during test to maintain junction temperature as close to ambient as possible.  
 $T_{low} = 0^\circ\text{C}$  for UC3844B, UC3845B       $T_{high} = +70^\circ\text{C}$  for UC3844B, UC3845B  
       =  $-25^\circ\text{C}$  for UC2844B, UC2845B      =  $+85^\circ\text{C}$  for UC2844B, UC2845B  
       =  $-40^\circ\text{C}$  for UC3844BV, UC3845BV      =  $+105^\circ\text{C}$  for UC3844BV, UC3845BV

**Figure 1. Timing Resistor versus Oscillator Frequency**

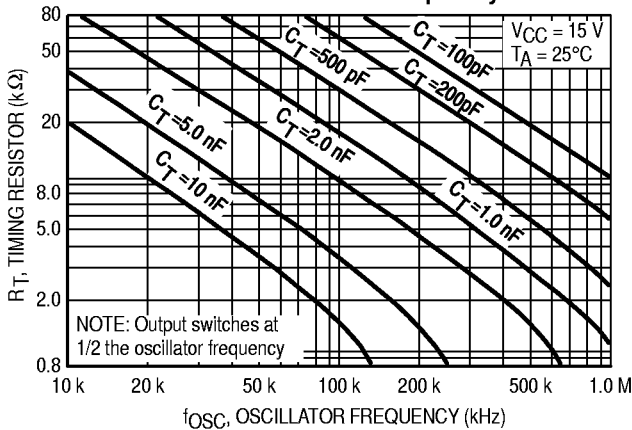

**Figure 2. Output Deadtime versus Oscillator Frequency**

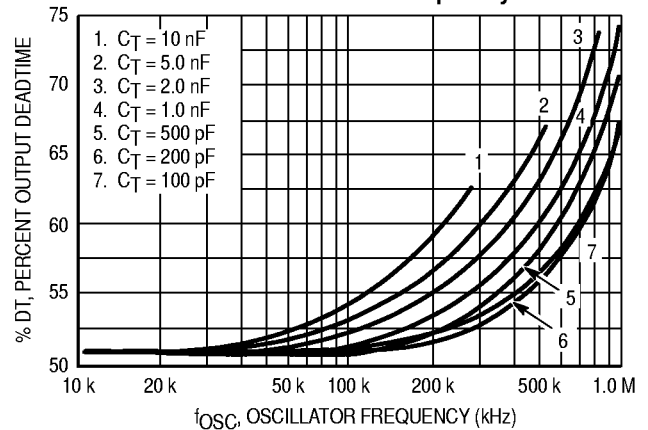

**Figure 3. Error Amp Small Signal Transient Response**

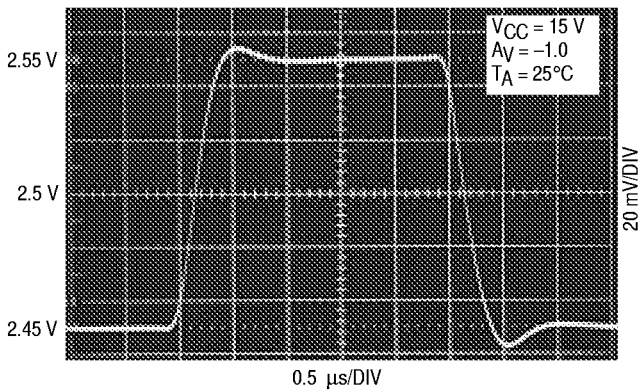

**Figure 4. Error Amp Large Signal Transient Response**

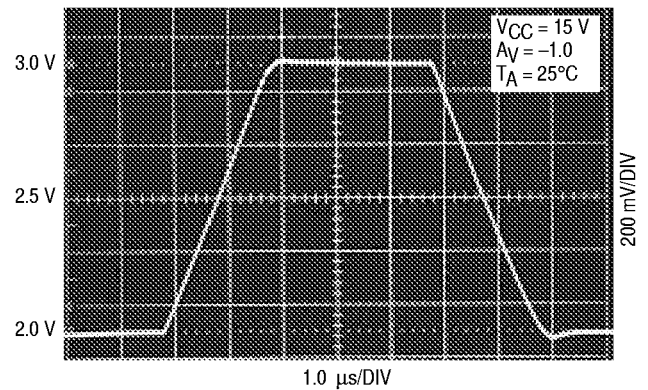

Figure 5. Error Amp Open Loop Gain and Phase versus Frequency

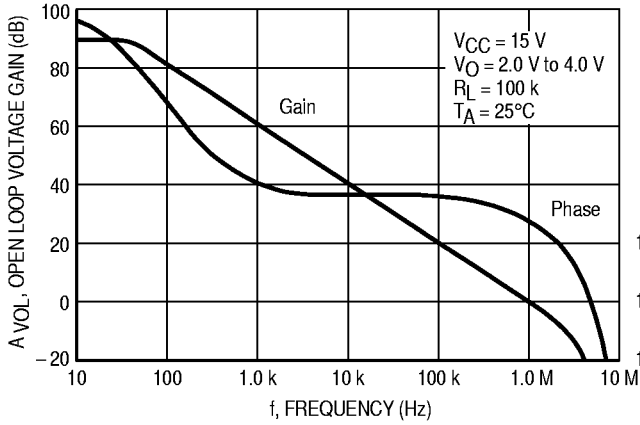

Figure 6. Current Sense Input Threshold versus Error Amp Output Voltage

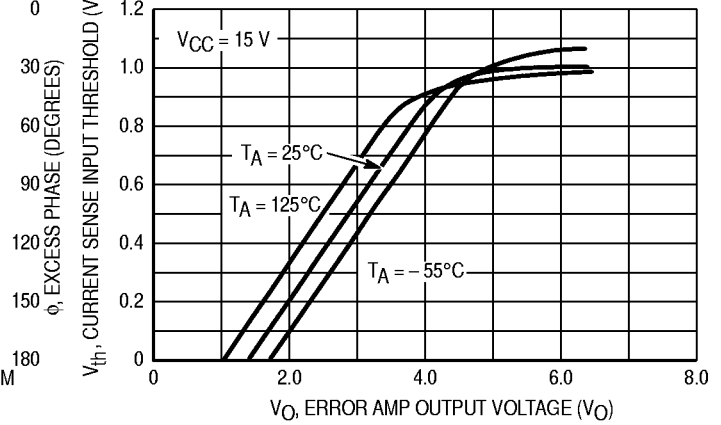

Figure 7. Reference Voltage Change versus Source Current

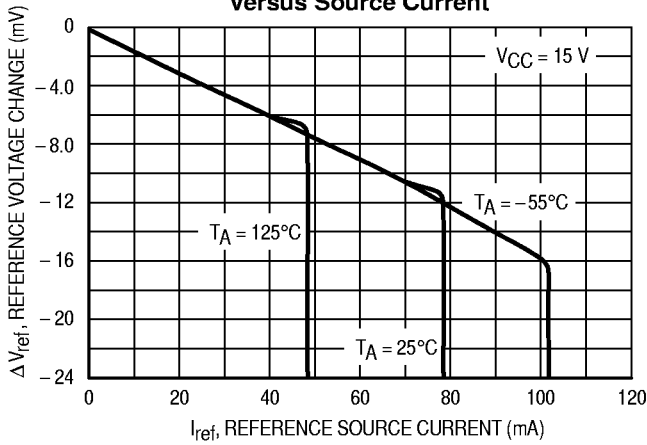

Figure 8. Reference Short Circuit Current versus Temperature

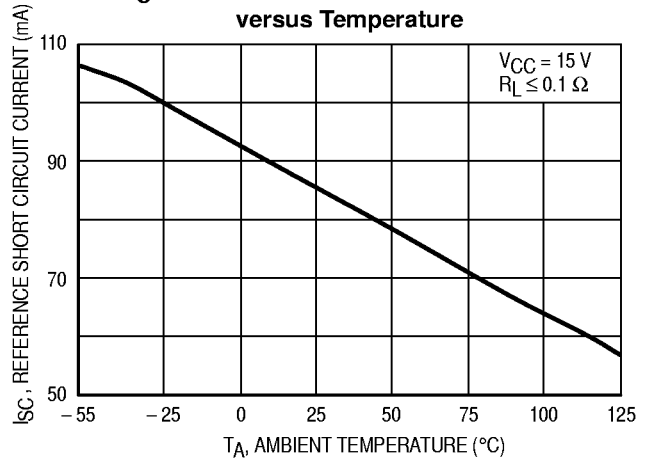

Figure 9. Reference Load Regulation

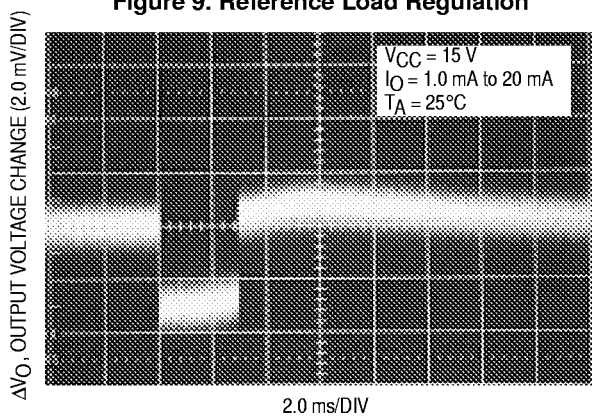

Figure 10. Reference Line Regulation

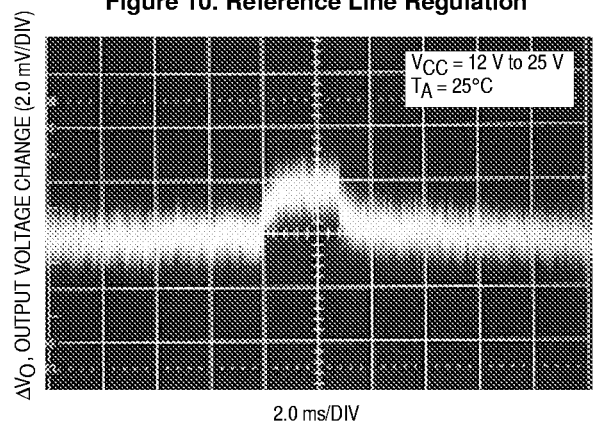

Figure 11. Output Saturation Voltage versus Load Current

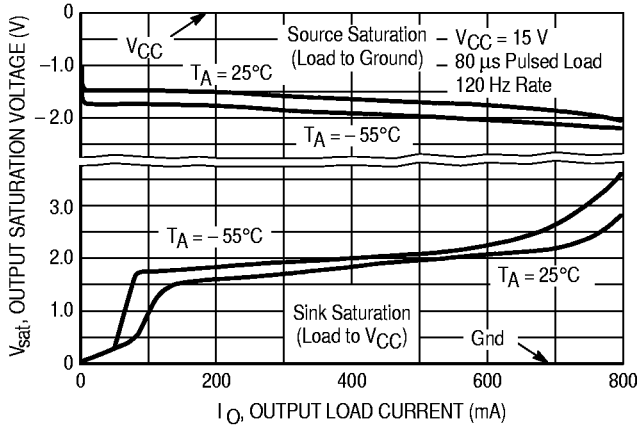

Figure 12. Output Waveform

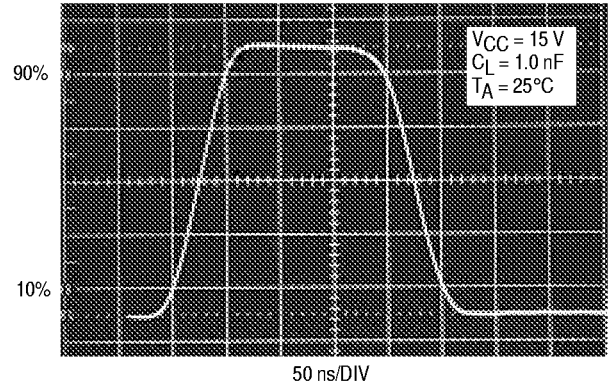

Figure 13. Output Cross Conduction

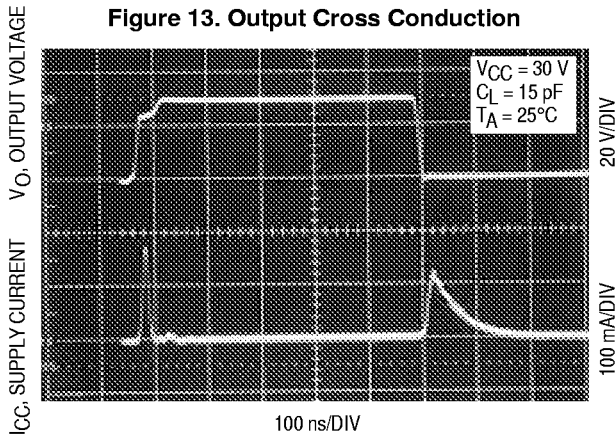
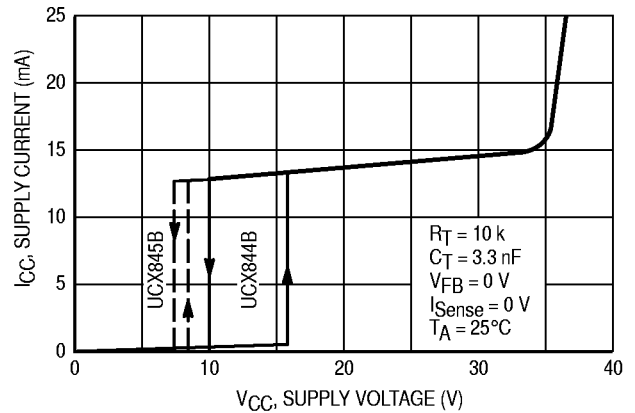

Figure 14. Supply Current versus Supply Voltage



PIN FUNCTION DESCRIPTION

| Pin   |          | Function         | Description  |
|-------|----------|------------------|--|
| 8-Pin | 14-Pin   |                  |  |
| 1     | 1        | Compensation     | This pin is the Error Amplifier output and is made available for loop compensation.  |
| 2     | 3        | Voltage Feedback | This is the inverting input of the Error Amplifier. It is normally connected to the switching power supply output through a resistor divider.  |
| 3     | 5        | Current Sense    | A voltage proportional to inductor current is connected to this input. The PWM uses this information to terminate the output switch conduction.  |
| 4     | 7        | RT/CT            | The Oscillator frequency and maximum Output duty cycle are programmed by connecting resistor RT to Vref and capacitor CT to ground. Oscillator operation to 1.0 kHz is possible.                 |
| 5     |          | Gnd              | This pin is the combined control circuitry and power ground.   |
| 6     | 10       | Output           | This output directly drives the gate of a power MOSFET. Peak currents up to 1.0 A are sourced and sunk by this pin. The output switches at one-half the oscillator frequency.                    |
| 7     | 12       | VCC              | This pin is the positive supply of the control IC.   |
| 8     | 14       | Vref             | This is the reference output. It provides charging current for capacitor CT through resistor RT.   |
|       | 8        | Power Ground     | This pin is a separate power ground return that is connected back to the power source. It is used to reduce the effects of switching transient noise on the control circuitry.                   |
|       | 11       | VC               | The Output high state (VOH) is set by the voltage applied to this pin. With a separate power source connection, it can reduce the effects of switching transient noise on the control circuitry. |
|       | 9        | Gnd              | This pin is the control circuitry ground return and is connected back to the power source ground.  |
|       | 2,4,6,13 | NC               | No connection. These pins are not internally connected.  |

## OPERATING DESCRIPTION

The UC3844B, UC3845B series are high performance, fixed frequency, current mode controllers. They are specifically designed for Off-Line and dc-to-dc converter applications offering the designer a cost-effective solution with minimal external components. A representative block diagram is shown in Figure 15.

**Oscillator**

The oscillator frequency is programmed by the values selected for the timing components  $R_T$  and  $C_T$ . Capacitor  $C_T$  is charged from the 5.0 V reference through resistor  $R_T$  to approximately 2.8 V and discharged to 1.2 V by an internal current sink. During the discharge of  $C_T$ , the oscillator generates an internal blanking pulse that holds the center input of the NOR gate high. This causes the Output to be in a low state, thus producing a controlled amount of output deadtime. An internal flip-flop has been incorporated in the UCX844/5B which blanks the output off every other clock cycle by holding one of the inputs of the NOR gate high. This in combination with the  $C_T$  discharge period yields output deadtimes programmable from 50% to 70%. Figure 1 shows  $R_T$  versus Oscillator Frequency and Figure 2, Output Deadtime versus Frequency, both for given values of  $C_T$ . Note that many values of  $R_T$  and  $C_T$  will give the same oscillator frequency but only one combination will yield a specific output deadtime at a given frequency. The oscillator thresholds are temperature compensated to within  $\pm 6\%$  at 50 kHz. Also, because of industry trends moving the UC384X into higher and higher frequency applications, the UC384XB is guaranteed to within  $\pm 10\%$  at 250 kHz.

In many noise-sensitive applications it may be desirable to frequency-lock the converter to an external system clock. This can be accomplished by applying a clock signal to the circuit shown in Figure 17. For reliable locking, the free-running oscillator frequency should be set about 10% less than the clock frequency. A method for multi-unit synchronization is shown in Figure 18. By tailoring the clock waveform, accurate Output duty cycle clamping can be achieved to realize output deadtimes of greater than 70%.

**Error Amplifier**

A fully compensated Error Amplifier with access to the inverting input and output is provided. It features a typical dc voltage gain of 90 dB, and a unity gain bandwidth of 1.0 MHz with 57 degrees of phase margin (Figure 5). The non-inverting input is internally biased at 2.5 V and is not pinned out. The converter output voltage is typically divided down and monitored by the inverting input. The maximum input bias current is  $-2.0 \mu\text{A}$  which can cause an output voltage error that is equal to the product of the input bias current and the equivalent input divider source resistance.

The Error Amp Output (Pin 1) is provided for external loop compensation (Figure 28). The output voltage is offset by two diode drops ( $\approx 1.4 \text{ V}$ ) and divided by three before it connects to the inverting input of the Current Sense Comparator. This guarantees that no drive pulses appear at the Output (Pin 6) when Pin 1 is at its lowest state ( $V_{OL}$ ). This occurs when the

power supply is operating and the load is removed, or at the beginning of a soft-start interval (Figures 20, 21). The Error Amp minimum feedback resistance is limited by the amplifier's source current (0.5 mA) and the required output voltage ( $V_{OH}$ ) to reach the comparator's 1.0 V clamp level:

$$R_{f(\text{min})} \approx \frac{3.0 (1.0 \text{ V}) + 1.4 \text{ V}}{0.5 \text{ mA}} = 8800 \Omega$$

**Current Sense Comparator and PWM Latch**

The UC3844B, UC3845B operate as a current mode controller, whereby output switch conduction is initiated by the oscillator and terminated when the peak inductor current reaches the threshold level established by the Error Amplifier Output/Compensation (Pin 1). Thus the error signal controls the peak inductor current on a cycle-by-cycle basis. The Current Sense Comparator PWM Latch configuration used ensures that only a single pulse appears at the Output during any given oscillator cycle. The inductor current is converted to a voltage by inserting the ground-referenced sense resistor  $R_S$  in series with the source of output switch Q1. This voltage is monitored by the Current Sense Input (Pin 3) and compared to a level derived from the Error Amp Output. The peak inductor current under normal operating conditions is controlled by the voltage at Pin 1 where:

$$I_{pk} = \frac{V(\text{Pin 1}) - 1.4 \text{ V}}{3 R_S}$$

Abnormal operating conditions occur when the power supply output is overloaded or if output voltage sensing is lost. Under these conditions, the Current Sense Comparator threshold will be internally clamped to 1.0 V. Therefore the maximum peak switch current is:

$$I_{pk(\text{max})} = \frac{1.0 \text{ V}}{R_S}$$

When designing a high power switching regulator it becomes desirable to reduce the internal clamp voltage in order to keep the power dissipation of  $R_S$  to a reasonable level. A simple method to adjust this voltage is shown in Figure 19. The two external diodes are used to compensate the internal diodes, yielding a constant clamp voltage over temperature. Erratic operation due to noise pickup can result if there is an excessive reduction of the  $I_{pk(\text{max})}$  clamp voltage.

A narrow spike on the leading edge of the current waveform can usually be observed and may cause the power supply to exhibit an instability when the output is lightly loaded. This spike is due to the power transformer interwinding capacitance and output rectifier recovery time. The addition of an RC filter on the Current Sense Input with a time constant that approximates the spike duration will usually eliminate the instability (refer to Figure 23).

# UC3844B, 45B UC2844B, 45B

Figure 15. Representative Block Diagram

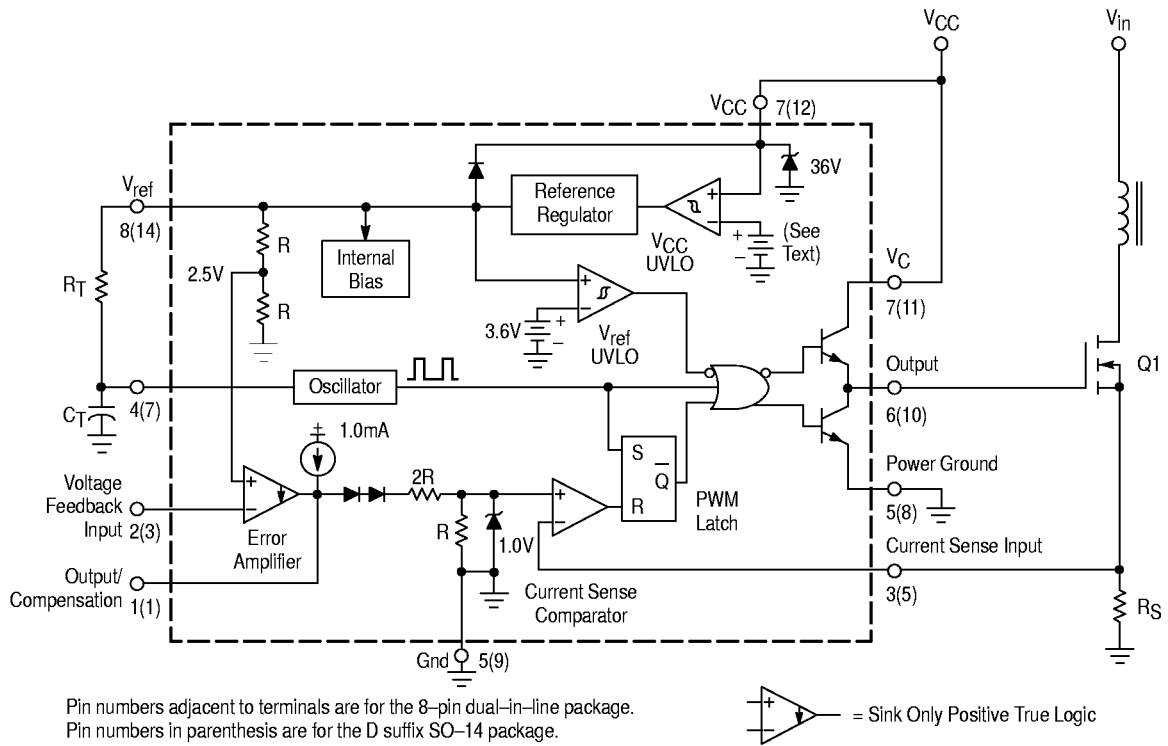
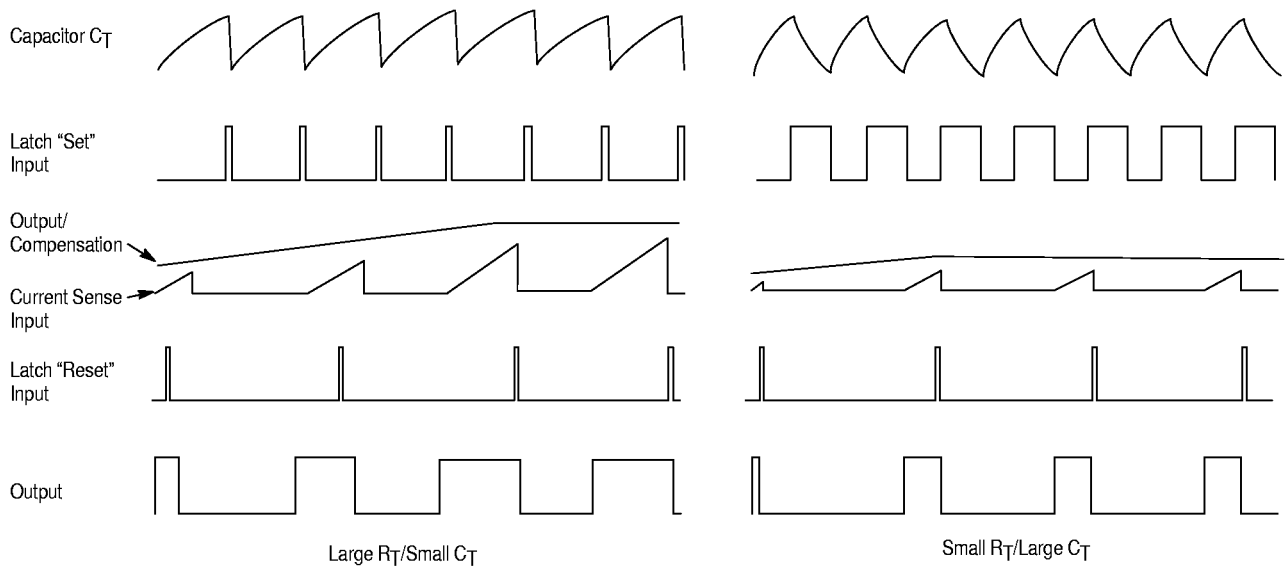

Figure 16. Timing Diagram



**Undervoltage Lockout**

Two undervoltage lockout comparators have been incorporated to guarantee that the IC is fully functional before the output stage is enabled. The positive power supply terminal ( $V_{CC}$ ) and the reference output ( $V_{ref}$ ) are each monitored by separate comparators. Each has built-in hysteresis to prevent erratic output behavior as their respective thresholds are crossed. The  $V_{CC}$  comparator upper and lower thresholds are 16 V/10 V for the UCX844B, and 8.4 V/7.6 V for the UCX845B. The  $V_{ref}$  comparator upper and lower thresholds are 3.6 V/3.4 V. The large hysteresis and low startup current of the UCX844B makes it ideally suited in off-line converter applications where efficient bootstrap startup techniques are required (Figure 29). The UCX845B is intended for lower voltage dc-to-dc converter applications. A 36 V zener is connected as a shunt regulator from  $V_{CC}$  to ground. Its purpose is to protect the IC from excessive voltage that can occur during system startup. The minimum operating voltage for the UCX844B is 11 V and 8.2 V for the UCX845B.

**Output**

These devices contain a single totem pole output stage that was specifically designed for direct drive of power MOSFETs. It is capable of up to  $\pm 1.0$  A peak drive current and has a typical rise and fall time of 50 ns with a 1.0 nF load. Additional internal circuitry has been added to keep the Output in a sinking mode whenever an undervoltage lockout is active. This characteristic eliminates the need for an external pull-down resistor.

The SO-14 surface mount package provides separate pins for  $V_C$  (output supply) and Power Ground. Proper implementation will significantly reduce the level of switching transient noise imposed on the control circuitry. This becomes particularly useful when reducing the  $I_{pk(max)}$  clamp level. The separate  $V_C$  supply input allows the designer

added flexibility in tailoring the drive voltage independent of  $V_{CC}$ . A zener clamp is typically connected to this input when driving power MOSFETs in systems where  $V_{CC}$  is greater than 20 V. Figure 22 shows proper power and control ground connections in a current-sensing power MOSFET application.

**Reference**

The 5.0 V bandgap reference is trimmed to  $\pm 1.0\%$  tolerance at  $T_J = 25^\circ\text{C}$  on the UC284XB, and  $\pm 2.0\%$  on the UC384XB. Its primary purpose is to supply charging current to the oscillator timing capacitor. The reference has short-circuit protection and is capable of providing in excess of 20 mA for powering additional control system circuitry.

**Design Considerations**

**Do not attempt to construct the converter on wire-wrap or plug-in prototype boards.** High frequency circuit layout techniques are imperative to prevent pulse-width jitter. This is usually caused by excessive noise pick-up imposed on the Current Sense or Voltage Feedback inputs. Noise immunity can be improved by lowering circuit impedances at these points. The printed circuit layout should contain a ground plane with low-current signal and high-current switch and output grounds returning on separate paths back to the input filter capacitor. Ceramic bypass capacitors (0.1  $\mu\text{F}$ ) connected directly to  $V_{CC}$ ,  $V_C$ , and  $V_{ref}$  may be required depending upon circuit layout. This provides a low impedance path for filtering the high frequency noise. All high current loops should be kept as short as possible using heavy copper runs to minimize radiated EMI. The Error Amp compensation circuitry and the converter output voltage divider should be located close to the IC and as far as possible from the power switch and other noise-generating components.

**Figure 17. External Clock Synchronization**

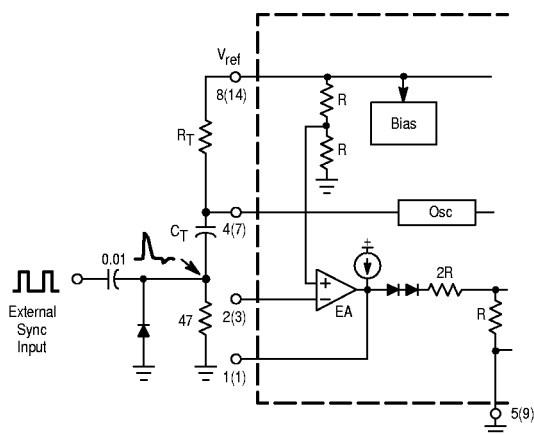

The diode clamp is required if the Sync amplitude is large enough to cause the bottom side of  $C_T$  to go more than 300 mV below ground.

**Figure 18. External Duty Cycle Clamp and Multi-Unit Synchronization**

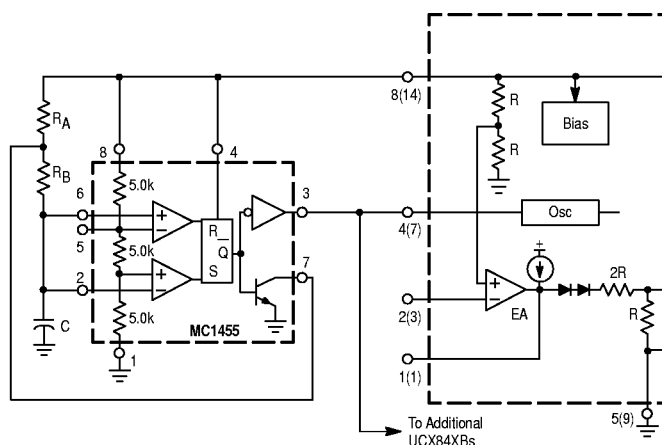

$$f = \frac{1.44}{(R_A + 2R_B)C} \quad D_{(max)} = \frac{R_A}{R_A + 2R_B}$$

Figure 19. Adjustable Reduction of Clamp Level

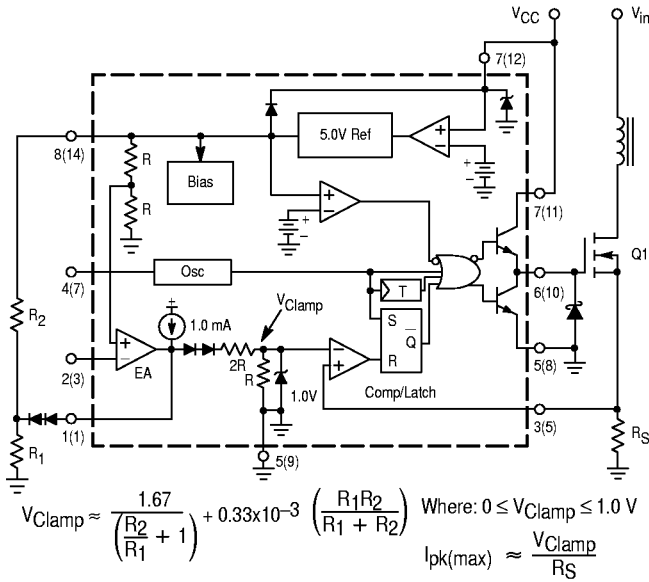

Figure 20. Soft-Start Circuit

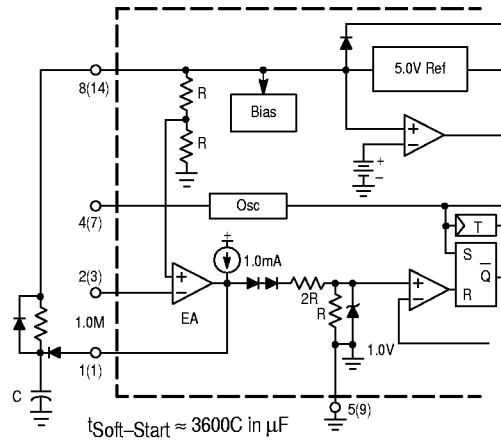

Figure 21. Adjustable Buffered Reduction of Clamp Level with Soft-Start

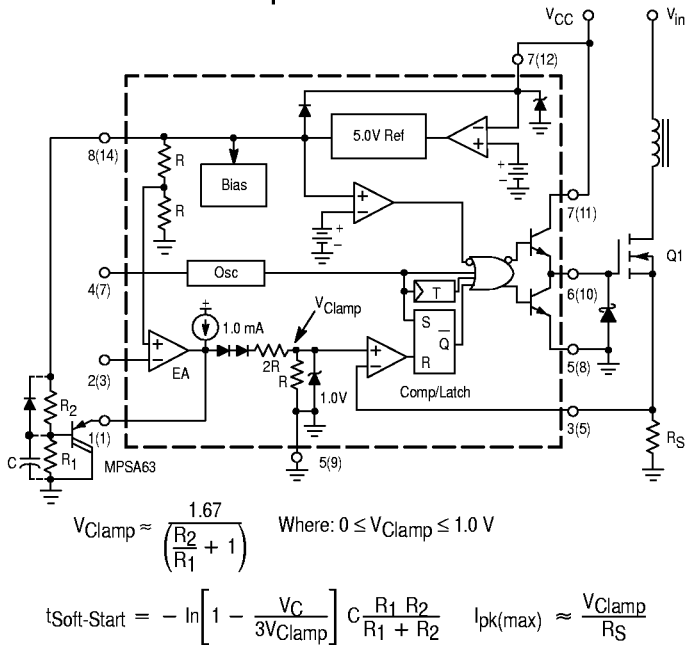
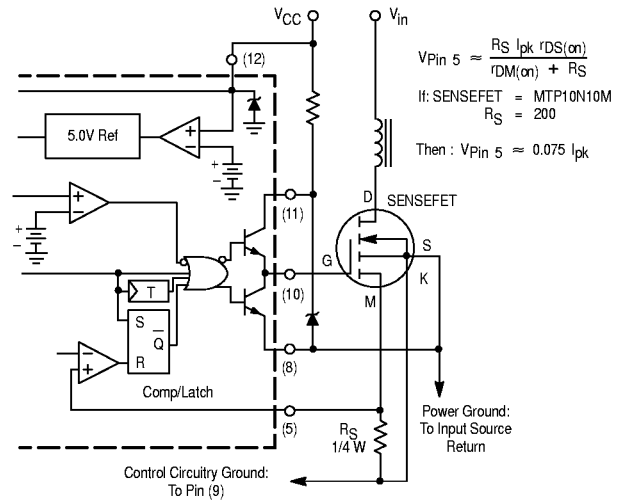

Figure 22. Current Sensing Power MOSFET



Virtually lossless current sensing can be achieved with the implementation of a SENSEFET power switch. For proper operation during over-current conditions, a reduction of the  $I_{pk(max)}$  clamp level must be implemented. Refer to Figures 19 and 21.

Figure 23. Current Waveform Spike Suppression

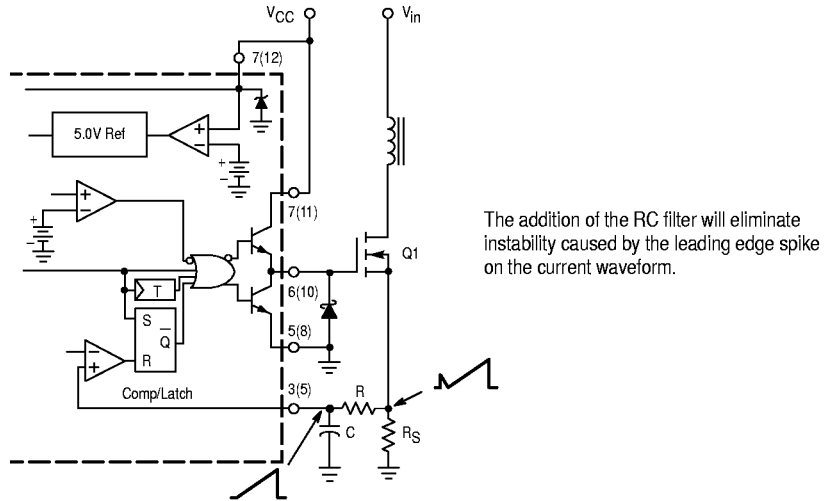
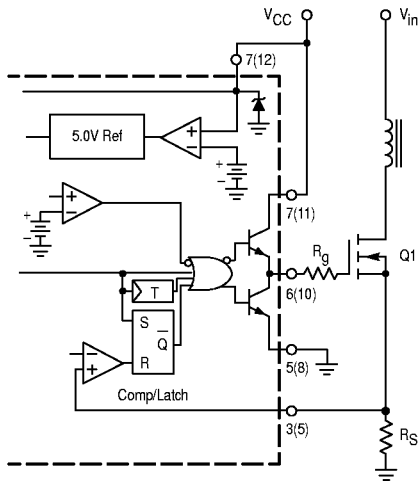
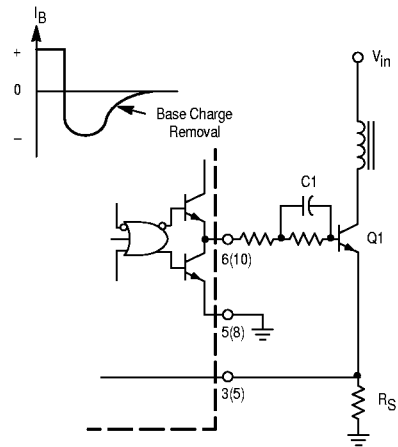

Figure 24. MOSFET Parasitic Oscillations



Series gate resistor  $R_g$  will damp any high frequency parasitic oscillations caused by the MOSFET input capacitance and any series wiring inductance in the gate-source circuit.

Figure 25. Bipolar Transistor Drive



The totem pole output can furnish negative base current for enhanced transistor turn-off, with the addition of capacitor C1.



# UC3844B, 45B UC2844B, 45B

Figure 29. 7 W Off-Line Flyback Regulator

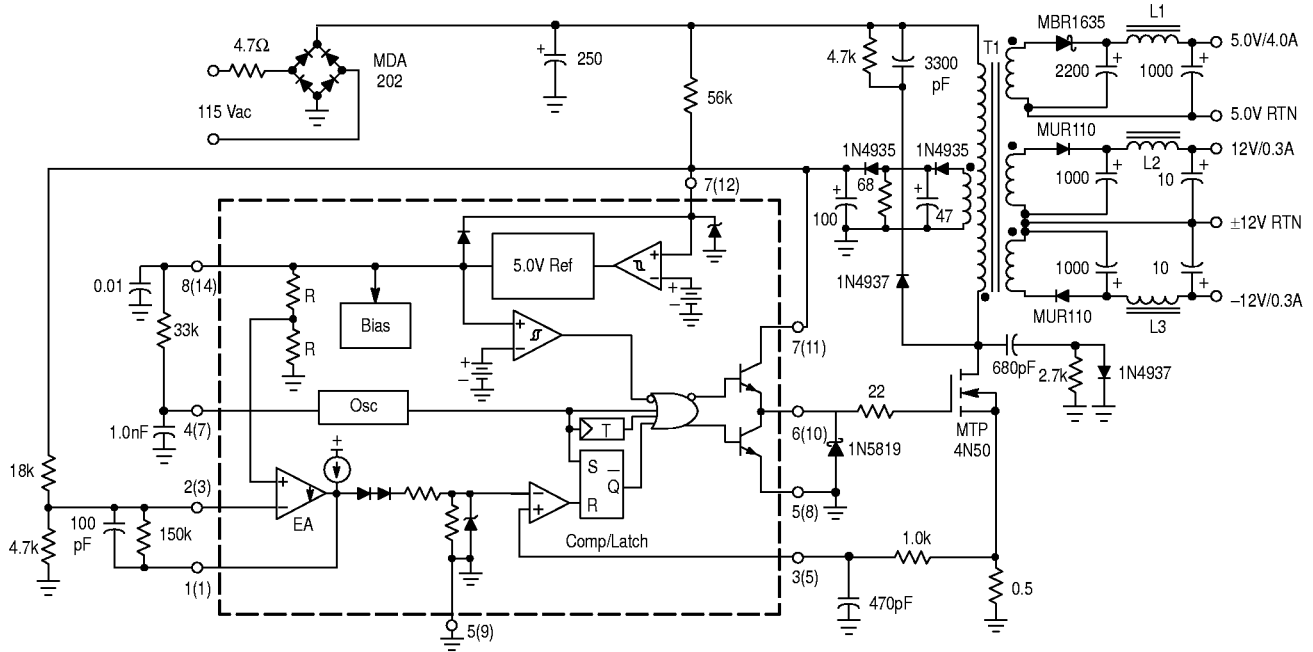

T1 –Primary: 45 Turns #26 AWG  
 Secondary ±12 V: 9 Turns #30 AWG (2 Strands) Bifilar Wound  
 Secondary 5.0 V: 4 Turns (six strands) #26 Hexfililar Wound  
 Secondary Feedback: 10 Turns #30 AWG (2 strands) Bifilar Wound  
 Core: Ferroxcube EC35–3C8  
 Bobbin: Ferroxcube EC35PCB1  
 Gap:  $\approx 0.10''$  for a primary inductance of 1.0 mH

L1 – 15  $\mu$ H at 5.0 A, Coilcraft Z7156  
 L2, L3 – 25  $\mu$ H at 5.0 A, Coilcraft Z7157

| Test                            | Conditions   | Results  |
|---------------------------------|--|--|
| Line Regulation: 5.0 V<br>±12 V | $V_{in} = 95 \text{ Vac to } 130 \text{ Vac}$  | $\Delta = 50 \text{ mV or } \pm 0.5\%$<br>$\Delta = 24 \text{ mV or } \pm 0.1\%$   |
| Load Regulation: 5.0 V<br>±12 V | $V_{in} = 115 \text{ Vac, } I_{out} = 1.0 \text{ A to } 4.0 \text{ A}$<br>$V_{in} = 115 \text{ Vac, } I_{out} = 100 \text{ mA to } 300 \text{ mA}$ | $\Delta = 300 \text{ mV or } \pm 3.0\%$<br>$\Delta = 60 \text{ mV or } \pm 0.25\%$ |
| Output Ripple: 5.0 V<br>±12 V   | $V_{in} = 115 \text{ Vac}$   | 40 mV <sub>pp</sub><br>80 mV <sub>pp</sub>   |
| Efficiency                      | $V_{in} = 115 \text{ Vac}$   | 70%  |

All outputs are at nominal load currents unless otherwise noted.

# UC3844B, 45B UC2844B, 45B

Figure 30. Step-Up Charge Pump Converter

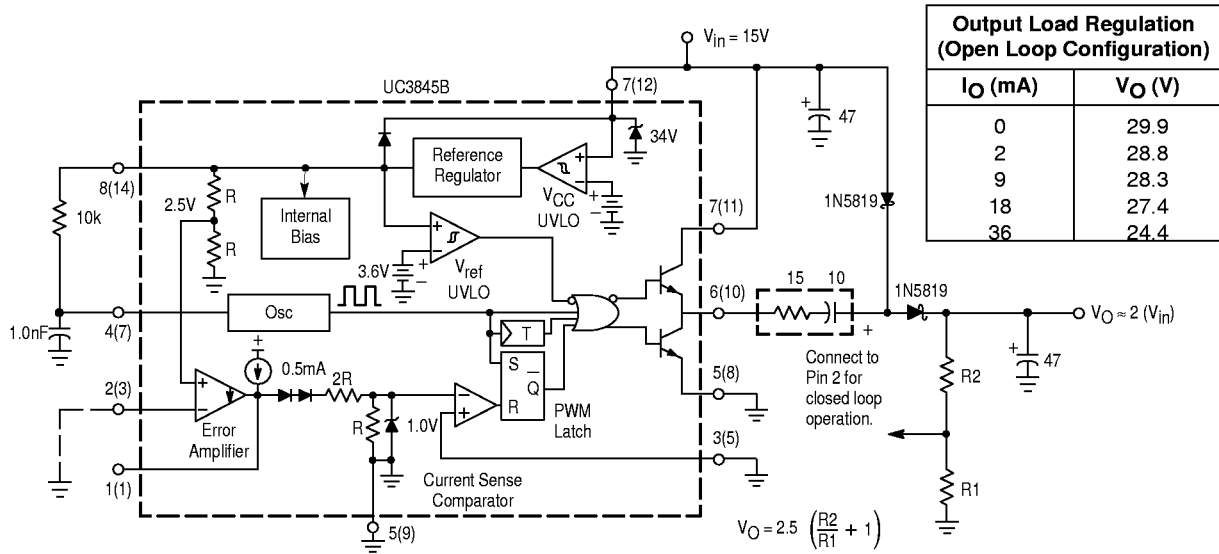

The capacitor's equivalent series resistance must limit the Drive Output current to 1.0 A. An additional series resistor may be required when using tantalum or other low ESR capacitors. The converter's output can provide excellent line and load regulation by connecting the R2/R1 resistor divider as shown.

Figure 31. Voltage-Inverting Charge Pump Converter

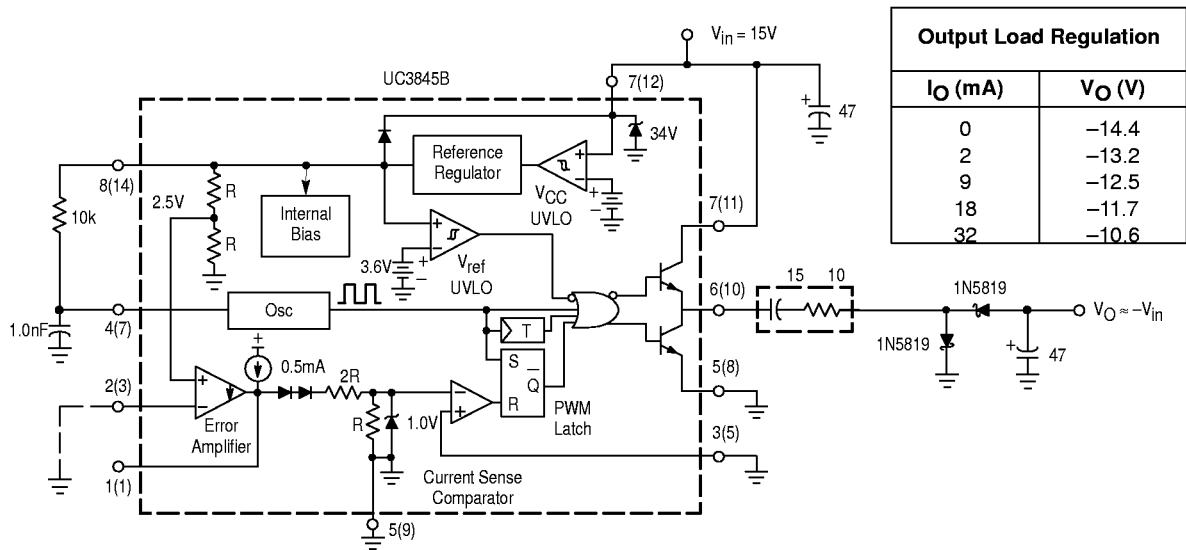

The capacitor's equivalent series resistance must limit the Drive Output current to 1.0 A. An additional series resistor may be required when using tantalum or other low ESR capacitors.

## OUTLINE DIMENSIONS



# UC3844B, 45B UC2844B, 45B

## OUTLINE DIMENSIONS

**D SUFFIX**  
**PLASTIC PACKAGE**  
**CASE 751A-03**  
**(SO-14)**  
**ISSUE F**

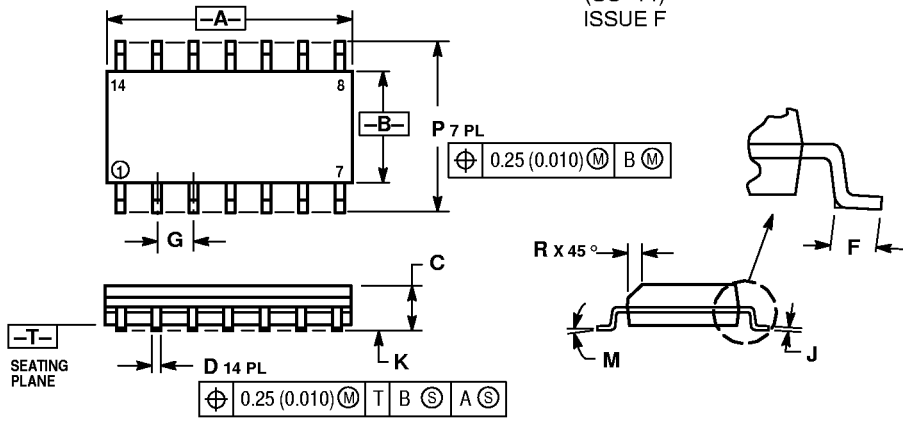

**NOTES:**

1. DIMENSIONING AND TOLERANCING PER ANSI Y14.5M, 1982.
2. CONTROLLING DIMENSION: MILLIMETER.
3. DIMENSIONS A AND B DO NOT INCLUDE MOLD PROTRUSION.
4. MAXIMUM MOLD PROTRUSION 0.15 (0.006) PER SIDE.
5. DIMENSION D DOES NOT INCLUDE DAMBAR PROTRUSION. ALLOWABLE DAMBAR PROTRUSION SHALL BE 0.127 (0.005) TOTAL IN EXCESS OF THE D DIMENSION AT MAXIMUM MATERIAL CONDITION.

| DIM | MILLIMETERS |      | INCHES    |       |
|-----|-------------|------|-----------|-------|
|     | MIN         | MAX  | MIN       | MAX   |
| A   | 8.55        | 8.75 | 0.337     | 0.344 |
| B   | 3.80        | 4.00 | 0.150     | 0.157 |
| C   | 1.35        | 1.75 | 0.054     | 0.068 |
| D   | 0.35        | 0.49 | 0.014     | 0.019 |
| F   | 0.40        | 1.25 | 0.016     | 0.049 |
| G   | 1.27 BSC    |      | 0.050 BSC |       |
| J   | 0.19        | 0.25 | 0.008     | 0.009 |
| K   | 0.10        | 0.25 | 0.004     | 0.009 |
| M   | 0°          | 7°   | 0°        | 7°    |
| P   | 5.80        | 6.20 | 0.228     | 0.244 |
| R   | 0.25        | 0.50 | 0.010     | 0.019 |

Motorola reserves the right to make changes without further notice to any products herein. Motorola makes no warranty, representation or guarantee regarding the suitability of its products for any particular purpose, nor does Motorola assume any liability arising out of the application or use of any product or circuit, and specifically disclaims any and all liability, including without limitation consequential or incidental damages. "Typical" parameters which may be provided in Motorola data sheets and/or specifications can and do vary in different applications and actual performance may vary over time. All operating parameters, including "Typicals" must be validated for each customer application by customer's technical experts. Motorola does not convey any license under its patent rights nor the rights of others. Motorola products are not designed, intended, or authorized for use as components in systems intended for surgical implant into the body, or other applications intended to support or sustain life, or for any other application in which the failure of the Motorola product could create a situation where personal injury or death may occur. Should Buyer purchase or use Motorola products for any such unintended or unauthorized application, Buyer shall indemnify and hold Motorola and its officers, employees, subsidiaries, affiliates, and distributors harmless against all claims, costs, damages, and expenses, and reasonable attorney fees arising out of, directly or indirectly, any claim of personal injury or death associated with such unintended or unauthorized use, even if such claim alleges that Motorola was negligent regarding the design or manufacture of the part. Motorola and  registered trademarks of Motorola, Inc. Motorola, Inc. is an Equal Opportunity/Affirmative Action Employer.

**How to reach us:**

**USA / EUROPE / Locations Not Listed:** Motorola Literature Distribution;  
 P.O. Box 20912; Phoenix, Arizona 85036. 1-800-441-2447 or 602-303-5454

**JAPAN:** Nippon Motorola Ltd.; Tatsumi-SPD-JLDC, 6F Seibu-Butsuryu-Center,  
 3-14-2 Tatsumi Koto-Ku, Tokyo 135, Japan. 03-81-3521-8315

**MFAX:** RMFAX0@email.sps.mot.com - TOUCHTONE 602-244-6609  
**INTERNET:** http://Design-NET.com

**ASIA/PACIFIC:** Motorola Semiconductors H.K. Ltd.; 8B Tai Ping Industrial Park,  
 51 Ting Kok Road, Tai Po, N.T., Hong Kong. 852-26629298



UC3844B/D

